

HSF RoHS

REV	ECN NO	DESCRIPTION	DATE	NAME
A	—	NEW	11/23-'19	ZCD

CKT	DIM A	DIM B	DIM C	DIM D
2	0.6	1.36	3.00	2.35
4	1.80	2.56	4.20	3.55
5	2.40	3.16	4.80	4.15
6	3.00	3.76	5.40	4.75
7	3.60	4.36	6.00	5.35
8	4.20	4.96	6.60	5.95
10	5.40	6.16	7.80	7.15
12	6.60	7.36	9.00	8.35
14	7.80	8.56	10.20	9.55
16	9.00	9.76	11.40	10.75

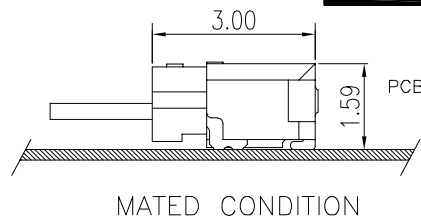
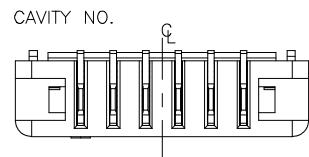
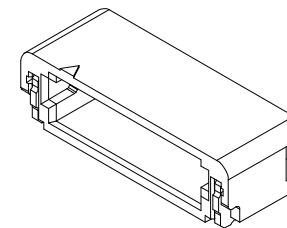

Main Specifications
Poles: 02 to 16
Contact resistance: ≤40m Ω
Insulation resistance: ≥100M Ω
Rated voltage: 30V AC DC
Rated current: 0.2A AC DC
Withstand Voltage: 100V AC/minute
Temperature Range: -55°C~+85°C

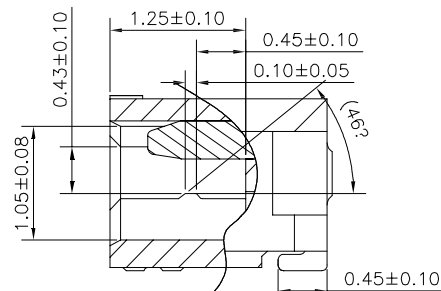
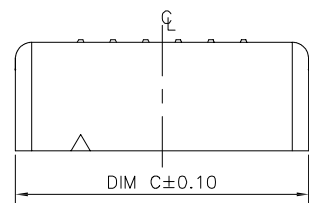

Ordering Information

L0601AWR-XX-FOKX1-R

PART No. _____

No. OF CIRCUITS: _____

02~16

PLASTIC MATERIAL: _____

FOK=LCP(BLACK)

PACKAGING:

R=REEL

P=PE

Metal code:

1=PhosphorBronze

PLATING:

B=Matte Sn

C=GOLD FLASH

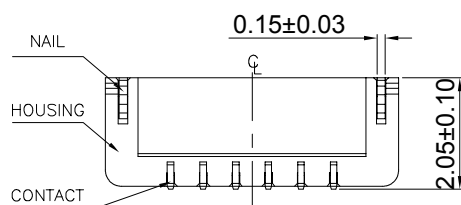
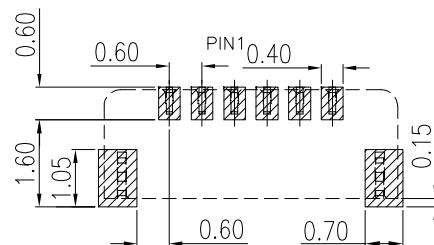
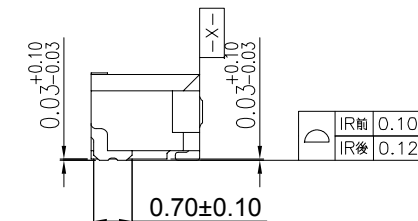
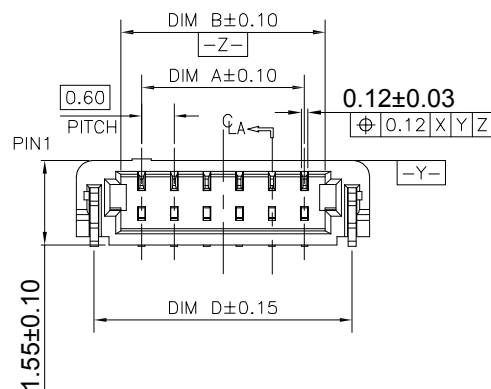

RECOMMEND PCB LAYOUT
 GENERAL TOLERANCE ±0.05

STANDARD TOLERANCE (EXCEPT SPECIFIED)

LINER	ANGLES
.0 ±0.30	0.° ±5°
.00 ±0.25	0.° ±2°
.000 ±0.10	.00° ±1°

ITEM	COMPONENT	Q'TY	MATERIAL	FINISH
C	SOLDER TAB	2 PCS	PhosphorBronze	MATTE Sn-plated
B	CONTACT	N PCS	PhosphorBronze	MATTE Sn-plated/GOLD FLASH
A	HOUSING	1 PCS	LCP	UL 94V-0, COLOR:BLACK

LDCONN 东莞连大精密制品有限公司
 连大 DongGuan LianDa Precision Products Co., LTD

TITLE	L0601AWR	DRAWN BY	ZCD	11/23-'19
PART NO.	L0601AWR-XX-FOKX1-R	CHECKED BY		
DRAWING NO.	—	APPROVED BY		
SCALE	1:1	UNIT	mm	PAGE 1/1
				SIZE A4